



Summer 2 Week 5

Year 3&4

This pack includes:

- Suggested Timetable
- Daily Reading session - approx. 30mins.
- Daily Spelling session - approx. 30 mins
- Topic Grid with activities to choose from

These activities in the grid cover a range of subjects across the curriculum. We recommend that you choose 3 activities per day but please do spend longer if particular tasks suit your interests.

Please complete work in your exercise book, for each lesson, and upload pictures to Microsoft Teams when finished.

This week's theme is: Out of this World

2

Key Words: astronaut, exploration, planet, meteor, comet, asteroid, gravity, lunar, solar



Click on these video hyperlinks to find out a little about our Solar System and Space exploration.

If you are unsure of the definition of some of these words, can you look them up in a dictionary?

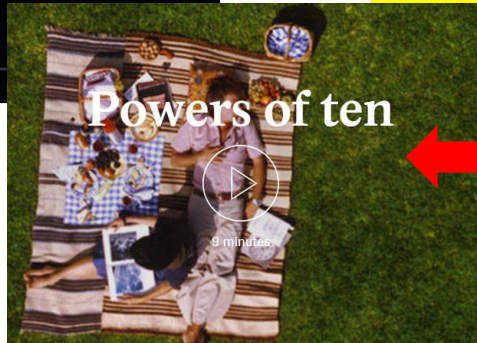

Optional Activity: Write down any questions you have about this topic. Can you answer any of your own questions by the end of the week?









Take some time to reflect. Would you like to travel into space? What skills and attributes would an astronaut need? Why?

Working From Home: Year 3/4 Timetable

Teachers: Miss Cole, Mrs Jones, Mr Sayer

Classes: Germany, Ireland, Brazil

Reading and spelling are in the same format as previous weeks (see following slides).

	9:00	9:30 - 10:00	Session 1 10:00 - 11:00		Session 2 11:30 - 12:30		1:30 - 2:00	Session 3 2:00-3:00	3:00 - 3:15
Monday	P.E.	Reading/ SPAG 	Choice 1 from Topic Grid	B	Choice 2 from Topic Grid	L	Spelling 	Choice 3 from Topic Grid	Check in on your Class Teams page and share what you have been up to.
Tuesday	P.E.	Reading/ SPAG 	Choice 4 from Topic Grid	R	Choice 5 from Topic Grid	U	Spelling 	Choice 6 from Topic Grid	
Wednesday	P.E.	Reading/ SPAG 	Choice 7 from Topic Grid	E	Choice 8 from Topic Grid	N	Spelling 	Choice 9 from Topic Grid	
Thursday	P.E.	Reading/ SPAG 	Choice 10 from Topic Grid	A	Choice 11 from Topic Grid	C	Spelling 	Choice 12 from Topic Grid	
Friday	P.E.	Reading/ SPAG 	Choice 13 from Topic Grid	K	Choice 14 from Topic Grid	H	Spelling Quiz/ Cracking Numbers/ Times Tables Practise	Choice 15 from Topic Grid	

Day 1 - Reading



Chapter 16 Top Price for Tilda

Unfortunately, Tilda Hacker was still very much a prisoner. The iron chains around her wrists and ankles reminded her of that. And she was scared. This was the first time she'd been put up for sale.

The market was crowded. A collection of traders sold their wares from simple table tops; they served eager customers with freshly roasted meats, roughly woven clothing, and crudely crafted cooking pots, wooden serving bowls and iron farming tools. Trade was brisk.

However, all that stopped as soon as the town's officious-looking auctioneer climbed onto a stack of

Please read Chapter 16.

Top Price for Tilda

hay bales and called for everyone's attention. His tone told them that the day's real business was about to begin.

It seemed that every Roman or Briton with a few coins to rub together had come to bid for a slave. And there were plenty to choose from: old ones, young ones, strong ones and weak ones. They were all available for the right price.

Tilda was attracting a lot of attention. In fact, she was the auctioneer's star lot. And she was scheduled to be sold next.

Two stocky Roman guards tugged on a pair of chains, dragging Tilda into the centre of the market square.

Tilda felt a rough hand squeeze her arm. "Plenty of fat on that," a voice yelled.

A strong hand yanked her hair. "Nice and healthy."

Somebody else prodded her in the back. "She's a strong 'un, alright. There's plenty 'o years of hard graft in her."

Tilda suddenly felt like a cow at a village fête. Couldn't these people see that she was a human being?

Roman Rescue

The auctioneer banged a heavy stick against the top of an ale barrel and the market fell silent.

"Next lot is a slave from the Emperor's house itself."

A ripple of enthusiasm swept through the crowd of would-be bidders.

"As you can see, she's not the usual specimen; our Roman masters haven't had time to beat the best years out of her yet, so you could be getting quite a bargain here."

A few eager bidders hollered and whooped.

"The Emperor wants top price, though," warned the auctioneer as he peered down at an unfurled scroll. "However, it does say here that he will give first refusal to any bidder offering a clean white donkey that has a 'go faster' cross on its back."

When nobody offered such a beast, the auctioneer continued.

"Okay, cash bids it is... will anyone start me off with two thousand silver denarii?"

Nobody responded.

"Come on," cried the auctioneer. "This is a prime northern female; the best we've seen in years. At two thousand silver denarii, I'm giving her away."

Still no response.

"Okay, one thousand. Will anyone bid one thousand silver denarii?"

"Five hundred!" yelled a voice from the back of the market.

"I have five hundred," acknowledged the auctioneer. "Will anyone give me six? Thank you, dear. We have six hundred from the farmer's wife at the front. Now, does anyone bid seven?"

"Seven!"

"A generous bid from the finely-dressed businessman... a man who clearly knows a quality product. But she's worth more than that... who will offer eight hundred?"



Charlie was still gasping. He had leapt from the manure

cart as soon as it had reached the outskirts of the village, and then desperately sprinted towards the crowded square, hoping that he wasn't too late.

Too small to see over the heads of the crowd, he leapt onto an upturned barrel and watched as excited men peppered the auctioneer with bids. They were all trying to buy Tilda!

"Eleven hundred dinarii!" hollered a toothless slave trader. He looked like he hadn't washed in months.

"Twelve hundred," screeched a wiry rival, carrying a piglet under his arm.

As the value climbed, Tilda looked more and more distressed. She had already given up trying to free her wrists from the biting iron shackles and now her desperate eyes scanned the crowd, clearly seeking a saviour.

Charlie waved his arms until his sister's eyes locked onto his. For a moment, relief drained her face of all distress and her lips moved silently: Help me, Charlie.

Her brother's nod seemed to reassure her for a moment but time was against Charlie. The bidding was slowing down and the auctioneer looked set to bring down his

gavel in a matter of seconds. Somehow, Charlie needed to come up with another escape plan, and fast!

There was so little he could do. Roman guards stood on sentry at every exit from the market. The auctioneer was surrounded by a ring of burly henchmen packing clubs the size of cricket bats. Charlie only had one option.

"FOURTEEN HUNDRED DINARII!" he bellowed at the top of his voice.

The entire bidding audience seemed to gasp as one. Even the auctioneer seemed a little stunned as he peered across the crowd at Charlie.

"Erm... I have a new bid from the... erm... the dwarf at the back."

"Fifteen hundred!" yelled the unwashed trader.

"Sixteen hundred!" Charlie screamed back.

"Seventeen!"

"Eighteen!"

The crowd grew silent and the atmosphere suddenly

became tense. This was serious money – the kind that only wealthy Romans and corrupt Britons had to spare.

“Nineteen!” Charlie’s rival was sweating, as if the tension was getting to him, too.

But Charlie didn’t care. It was quite fun spending money he didn’t have. He just hoped that by winning the auction, he would buy himself enough time to figure out how to free his sister. Paying for her wasn’t an option.

“Two thousand!” Charlie barked.

The people around him stared in disbelief. Some even backed away, as if scared by the price itself. For many in the crowd, two thousand dinarii was an amount they could only dream of.

“Do I hear a bid for two thousand and one hundred dinarii?” the auctioneer asked.

All eyes fell on Charlie’s rival bidder. Even the piglet tucked beneath his arm seemed to pause and look up at its master. Everyone waited for the man’s next bid.

But it never came. Instead, the man gave a stern shake of his head and a defeated wave from his hand.

The crowd cheered. Charlie had won!

Heavy hands slapped him on the back. Some punters even shook his hand. And women kissed his cheek. Then two sets of strong hands grabbed his arms.

“Nice bidding,” whispered a menacing voice. It belonged to one of the auctioneer’s huge henchmen. “Now it’s time to cough up.”

Day 2 - Reading

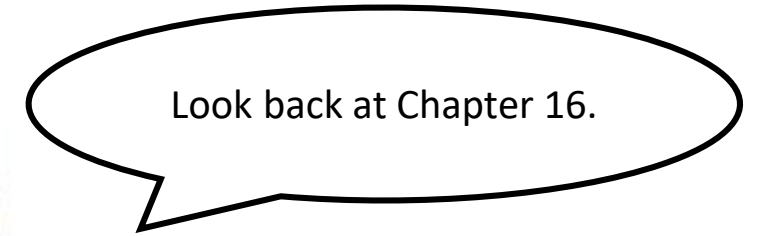

Chapter 16
Top Price for Tilda

- Can you use the description of the market to draw a labelled diagram.
- **Challenge!** Write your own description of the market, try to include all five senses.

Day 3 - Reading



Chapter 17

The Sweet Sound of Sirens

Charlie was half-carried, half-dragged to the auctioneer's podium. He hadn't expected things to happen so fast. There wasn't even time to gather his thoughts, never mind craft an escape plan.

Tilda was brought to meet him. Her iron chains were quickly removed and as she massaged her sore wrists, she shot her brother a look that seemed to ask him what he planned to do next.

"She's all yours," said the grinning auctioneer. If he was shocked to see that his winning customer was a boy, he didn't show it. "As soon as you hand over

Please read Chapter 17.
The final chapter!

The Sweet Sound of Sirens

my two thousand silver denarii."

Charlie gave his sister a feeble shrug as he said, "I think there might have been a small misunderstanding..."

The henchman's fingers gripped Charlie's arm like a police dog's bite.

"You see," Charlie continued, "...I thought that was the amount you were going to give me to take her off your hands."

"You mean you don't have my money?"

"Well, when you put it like that..." The throbbing veins on the auctioneer's neck told Charlie that this wasn't going to end well. "I suppose... no."

The auctioneer was shaking now and his entire face looked swollen and scalded.

"She's my sister," Charlie pleaded. "I need to get her back home."

The snarling auctioneer seized Charlie by his shirt and began to shake him like a toy. "Do you know what your little trick will do to my reputation? I'll be

Roman Rescue

laughed out of -"

Then the shaking stopped. Something small, round and glistening had just bounced out of Charlie's sock.

It hit the floor with a clank before twisting and spinning across the dust.

Slowly, the auctioneer released his grip on Charlie and smoothed down the creases in his shirt. A smile stretched his mouth as he crouched down to pluck the object off the ground.

"I thought you said you couldn't pay?"

The auctioneer held up the tiny golden signet ring that Charlie and Tilda had taken from Professor Howe's treasure vault. Its stone sparkled in the sunlight like a torch.

Everyone stared open-mouthed at the ring as if it was an alien from outer space. Charlie couldn't understand what was so special about it - nor did he care.

This was the opportunity he had been waiting for, so while the auctioneer and his henchmen were busy gazing at the ring, Charlie grabbed hold of Tilda's

hand and pulled her into the crowd.

At first, nobody said a word. People simply watched in stunned silence as the two children dashed through the marketplace as fast as their young legs would carry them.

Charlie thought they'd got away with it. Tilda, too. Until a booming voice chased after them.

"Stop those children!"

"Hurry!" gasped Charlie. "Let's get to the wall."

"I'm going as fast as I can," Tilda panted, but they knew it wasn't fast enough. The clatter of chasing footsteps was getting louder with every step.

As they emerged from a gap between two mud huts and left the village, Tilda pointed to a familiar-looking section of wall.

"It's there, hurry!"

"Don't we need the coins?" Charlie worried.

"Maybe we'll get lucky," Tilda hoped, even though the

tone of her voice betrayed an obvious lack of belief.

They could hear the panting breath of their pursuers, now only strides behind them. Summoning stamina and strength they didn't know they had, Charlie and Tilda made a final desperate dash. It seemed like they were going to make it right up until they were just metres from the wall, when one of the auctioneer's henchmen rugby-tackled them both. Charlie face-planted straight into the grass. Tilda crashed to earth beside him.

The auctioneer himself arrived moments later. His face was flushed red and he panted for breath like a retired greyhound.

"Why... did... you... run?" he gasped.

"It was our only chance," Charlie admitted.

"We had to try," Tilda nodded. "We don't belong here."

"But there's no need to run." The auctioneer waved the ring at them. "Not when you possess an item like this."

"Oh, sure," Tilda sneered. "I suppose you'd just let Charlie swap the ring for me?"

"Well, actually, yes," the auctioneer nodded. "If your brother is happy with such a transaction."

"Happy?" Charlie gasped. "Why wouldn't I be happy? It's not even m- ouch!"

Tilda kicked her brother's shin. "Is it valuable, then?"

"In the right hands, something like this could be almost priceless," the auctioneer confirmed. "This ring carries the Emperor's mark. These are only given to his most valued and trusted subjects."

Charlie shrugged "If it's so important, why did you chase us? You can have it if it means we can leave this awful place."

Bending close so he couldn't be overheard, the auctioneer whispered to the two children. "This ring doesn't belong to you, does it?"

Charlie shuffled awkwardly. "Erm, well..."

"I could get into a lot of trouble for accepting stolen property. Especially property like this." He dropped his voice even lower as he gave Tilda and Charlie a knowing wink. "But if it's really valuable, there might

be a reward for its return."

"We found it," Tilda interrupted. "We didn't steal it. It doesn't belong to anyone from this... erm... place."

"Good!" The auctioneer seemed relieved. "In that case, it'll be easier to sell. A ring bearing the Emperor's mark can open a lot of doors, and I know people who would give me several thousand denarii to get their hands on this."

Charlie and Tilda exchanged hopeful glances.

"Let me keep this ring and you can go free," the auctioneer promised.

Charlie didn't hesitate. He thrust his hand towards the auctioneer's, ready to give it a vigorous shake. He was about to say "Deal!" when Tilda stepped between them.

"I want something else."

Disappointment wrinkled the auctioneer's brow. "You do?"

Charlie echoed the man's question. "We do?"

The Sweet Sound of Sirens

"We need a key to get us home, remember?" Tilda's hushed words reminded him.

Tilda thrust her palm forward. "It would be awful if the Emperor ever found out that you had his ring. Give both of us a solid gold aureus and I guarantee you'll never see or hear from us again."

A second later, two golden coins were nestled in Tilda's hand. Her fingers snapped shut around them and before the auctioneer had the chance to change his mind, Tilda grabbed her younger brother by the wrist and yanked him towards the wall. She just had time to push one of the coins into Charlie's hand before she hurled them both straight at the ancient stonework.



Brother and sister collapsed breathlessly onto the soft, sweet grass of York's museum gardens. A few curious tourists glanced across at them, wondering why two children were wearing fancy dress. But on the whole, Charlie and Tilda's return to the twenty-first century went largely unnoticed.

Charlie could feel the sun beating down against his

back, but what kept him pinned to the floor was the soft and reassuring murmur that only comes from the gathering of summertime tourists. It was definitely a twenty-first-century sound. And they were definitely the same tourists he'd seen before they left. Which could only mean one thing: back in twenty-first-century York, they had only been gone for minutes, not days.

Tilda smiled as the beat of pop music filtered from the speakers in the museum café. Both children grinned happily at the distant howl of a police siren.

Minutes later, as they made their way back towards the antique shop, Charlie linked his arm around his sister's and held out the bag of Roman coins. "You know, I think we should give these to Dad to sell in the shop."

Tilda agreed. "We should probably give him all of Professor Howe's other coins too."

"Even the Viking coins?"

"Especially the Viking coins," Tilda insisted. "Apparently they were far worse than the Romans. And the Anglo-Saxons weren't much better either."

She paused to scratch her head. "Come to think of it, I'm not entirely sure if anywhere in the past is a good place to visit."

Charlie felt a little flutter of excitement rumble through his belly. "I guess there's only one way we'll ever really find out."

Day 4 and 5 - Reading

You can answer these questions over the next 2 days or complete one of the optional activities on slide 12 on Friday.



- Use what we know about Charlie to explain why he has acted the way he has.
- Do you think the author wants us to like the auctioneer? Why do you think this?
- Why do you think Professor Howe added a 'trinket' to each of the leather pouches?
- How has the character of the auctioneer changed over the chapter?
- What clues are we given that the auctioneer is a bit of a 'dodgy' character?
- How are Tilda's actions similar to the beginning of the story?
- Why do you think Charlie had forgotten about the signet ring?

Day 5 - Reading - Optional Activities

- Choose a time period and write a paragraph to persuade Charlie and Tilda to visit that period. You could then record this on a phone or tablet.
- Write a book review on Roman Rescue. You could use this template to help structure your work.

A suffix is a group of letters used at the end of a word to slightly change the word's meaning.

furious
glorious
victorious
mysterious
humorous
glamorous
odorous
nervous
adventurous
courageous

Spelling Rule: Adding the suffix 'ous'

In your workbook;

1. Practise writing these words.
2. Check the meanings of the words.
3. Write 2 sentences with two of your focus words in.

Remember, you could choose the alternative spellings instead.

because
whole
half
quarter
after
past
hour
minute
second
month

furious
glorious
victorious
mysterious
humorous
glamorous
odorous
nervous
adventurous
courageous

Spelling Quiz

With a grown up or sibling, complete a spelling quiz on all of your words.

How did you do? You could let your teacher know what you got out of 10.

because
whole
half
quarter
after
past
hour
minute
second
month



Try to complete at least 1 highlighted activity per day.

See next slides for further details.

<p>Maths: Silver Challenge (Daytime Feather) OR Gold Challenge (Football Cup) Clue 1 See worksheet in attachments.</p>	<p>Maths: Silver Challenge (Daytime Feather) OR Gold Challenge (Football Cup) Clue 2 See worksheet in attachments.</p>	<p>Maths: Silver Challenge (Daytime Feather) OR Gold Challenge (Football Cup) Clue 3 See worksheet in attachments.</p>	<p>Maths: Silver Challenge (Daytime Feather) OR Gold Challenge (Football Cup) Clue 4 (and 5) See worksheet in attachments.</p>	<p>Maths: Solar System Code Breaker See slides 20 and 21.</p>
<p>English (fiction): Listen to 'The Way Back Home' by Oliver Jeffers. Create a story map to show what happens. Re-write the story in your own words.</p>	<p>English (fiction): Listen to 'The Way Back Home' by Oliver Jeffers. Write a character description for the boy and the alien.</p>	<p>English (fiction): Listen to 'The Way Back Home' by Oliver Jeffers. Think of creative ways of helping the boy and the alien get back home.</p>	<p>English/History(non-fiction): Read the short report about the Apollo 11 Moon Landing. Research more facts about this famous event. (Lesson 1)</p>	<p>English/History(non-fiction): Read the short report about the Apollo 11 Moon Landing. Write your own report about The Moon Landing in 1969. (Lesson 2)</p>
<p>DT: Design a model rocket. (Lesson 1)</p> 	<p>DT: Create your model rocket using junk modelling materials. (Lesson 2)</p>	<p>DT: Design your own planet - you can use the template provided as a guide. (Lesson 1) See slide 22.</p>	<p>DT: Make your planet design using Papier-mâché. You can paint it and add details when it is dry. (Lesson 2)</p>	<p>Art: Use a chosen medium (e.g. crayons, chalk, paints) to create a picture of The Solar System.</p>
<p>English (Reading): Mars: The Red Planet Reading Comprehension See resources in attachments.</p>	<p>RE: Using what you have learned about Judaism this term, create a fact file about Jewish life. You could create this on the computer if you prefer.</p>	<p>French: Year 3 Project. See separate slide for more details. You can choose your year group project, the one that takes your interest or both! (slide 18)</p>	<p>French: Year 4 Project. See separate slide for more details. You can choose your year group project, the one that takes your interest or both! (slide 19)</p>	<p>Topic: Draw and label the planets of the solar system in order. Extension: Complete the Solar System Hunt (slides 25-27)</p>
<p>History: Look at the top 10 moments in space exploration: https://www.bbc.co.uk/news/science-environment-35326827. Plot these events on a timeline. Can you add any more events?</p>	<p>Topic: Read these stargazing tips and give it a go! https://www.nationaltrust.org.uk/features/top-tips-for-stargazing</p>	<p>Topic: Space Crossword See slide 23 and 24. Can you create your own space themed crossword using facts you have found out?</p>	<p>Topic: Space Word Search See slide 23. Can you practise spelling these words? Can you write them in a sentence?</p>	<p>Topic: Take a look at this website for lots more information and further activity ideas: https://spaceplace.nasa.gov/menu/do/</p>

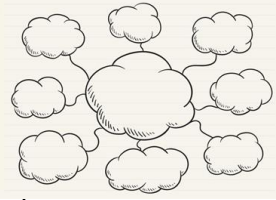

Activity Name	Instructions
<p>English (fiction): Create a story map to show what happens. Re-write the story in your own words.</p>	<p>Watch the story using the following link - https://www.youtube.com/watch?v=4nS8w-oCDac If you cannot access the link, you can write your own story about a space adventure. Remember to structure your story with a clear beginning, middle and end. Use your story map to help write your story. Try to use description, interesting vocabulary and a range of sentence starters.</p>
<p>English (fiction): Write a character description for the boy and the alien.</p>	<p>Watch the story using the following link - https://www.youtube.com/watch?v=4nS8w-oCDac Start by drawing a picture of the boy and of the alien. Remember to describe their looks, personality, behaviours and feelings. Try to pack your descriptions with expanded noun phrases (lots of adjectives).</p>
<p>English (fiction): Think of creative ways of helping the boy and the alien get back home.</p> 	<p>Watch the story using the following link - https://www.youtube.com/watch?v=4nS8w-oCDac In the story the boy and the alien think of ways to get back home. Create a mind map of ideas to show ways they could get back home e.g. jump on a shooting star and zoom back to Earth. Try to think of as many ideas as possible. Extension - Can you write a paragraph to describe the boy and the alien getting home in your chosen way.</p> 
<p>English/History(non-fiction): Research more facts about this famous event. (Lesson 1)</p>	<p>Read the basic report on the next slide (17). Research more facts about the Apollo 11 Moon Landing. Take notes to show what you have found out. You might find these websites helpful: https://www.penguin.co.uk/articles/children/2019/jul/facts-about-moon-landing-space-race-apollo-11.html https://kids.kiddle.co/Apollo_11</p>
<p>English/History(non-fiction): Write your own report about The Moon Landing in 1969. (Lesson 2)</p>	<p>Using the sub-headings on slide 17 as a guide to help structure your report, can you write a more detailed report about The Apollo 11 Moon Landing. Use the information you have been given as a start point then add some of the facts you noted down in lesson 1. Remember you can include pictures and captions too.</p>
<p>DT: Make your planet design using Papier-mâché. You can paint it and add details when it is dry. (Lesson 2)</p>	<p>Useful Links: How to make papier-mâché - https://www.bbcgoodfood.com/howto/guide/how-make-paper-mache How to make papier-mâché planets - https://www.instructables.com/id/Papier-Mache-Planets/ Although this second link shows how to make multiple planets, you can adapt to create the planet you designed.</p>

The Moon Landing

On July 20th 1969 Apollo 11 landed on the moon. There were 3 Astronauts on board - Neil Armstrong, Buzz Aldrin and Michael Collins.



When was it?

On July 16th the Apollo 11 was launched from Kennedy Space Centre in America. It took 3 whole days to get to the moon.



What happened?

Neil Armstrong and Buzz Aldrin walked on the moon for 2 hours 15 minutes. Michael Collins orbited the moon in the service-command module. They returned safely to Earth as heroes.



Did you know?

The Apollo 11 rocket was called Saturn V. It had 3 parts; the service module, the command module and the lunar module!

The Moon Landing Report:

Use these facts as a start point when it comes to writing your own report.

Remember to share your finished reports on Microsoft Teams.

French

Bonjour year 3

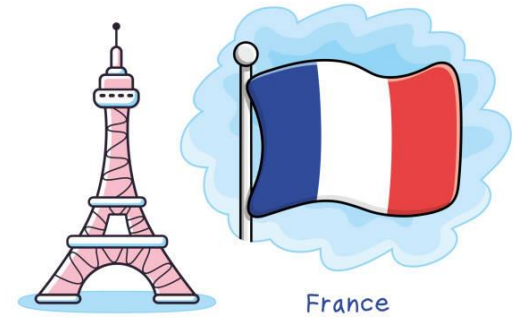

- For your French work this half term I thought you might enjoy another mini project. This one is called: **Un caméléon**. It is about a chameleon.



Aim of this project



- To design, write and make a lift-the-flap book to describe the colours of a chameleon
- It will show that you can use a French/English dictionary to find nouns, check whether they are masculine or feminine and write the correct word for 'a'.



- There is a video to watch which teaches you everything you need to know to make the book. <https://www.youtube.com/watch?v=xyv93Tyijus>
- You can pause the video (which lasts 27 minutes) as often as you like and do the project in small steps at your own pace.
- I'm really excited to see what you can make! Have fun!

French

Bonjour year 4

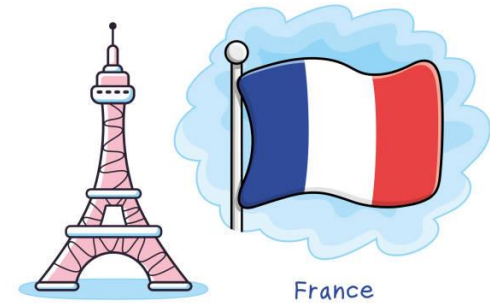

- For your French work this half term I thought you might enjoy another mini project. This one is called **Un animal extraordinaire**. It is about a chameleon.

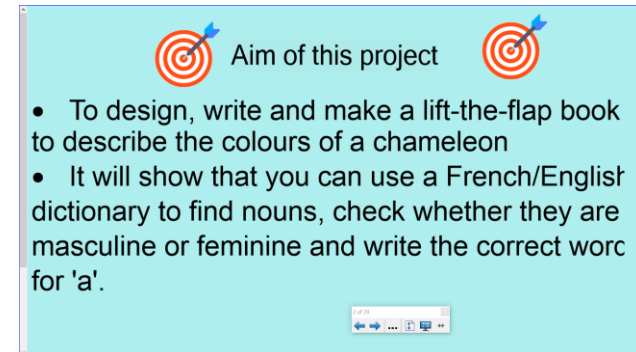

- There is a video to watch which teaches you everything you need to know. <https://www.youtube.com/watch?v=xyv93Tyijus>
- You can pause the video (which lasts 59 minutes) as often as you like and do the project in small steps at your own pace.
- I'm really excited to see what you can make! Have fun!

Solar System Code Breaker

Amazing Fact

The sun is so big that it could fit approximately 1.3 million Earths inside it (if they were squashed up).

Challenge

Crack the codes on the following pages using the table below to work out the solar system words.

a	b	c	d	e	f	g	h	i	j	k	l	m
1	2	3	4	5	6	7	8	9	10	11	12	13

n	o	p	q	r	s	t	u	v	w	x	y	z
14	15	16	17	18	19	20	21	22	23	24	25	26

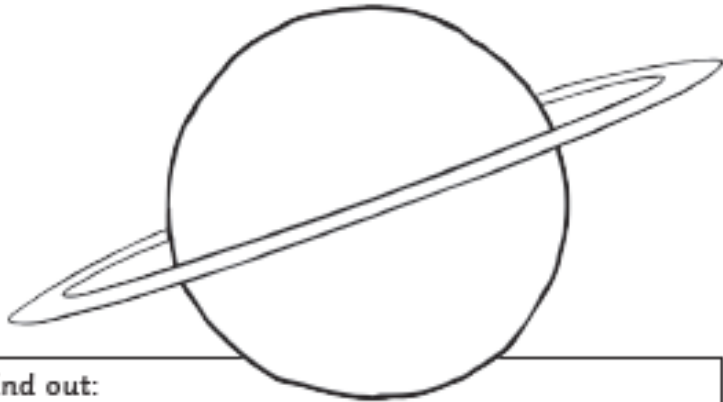

You could also try to find out:

- what the sun would look like from the other planets in our Solar System;
- what the biggest planet is in our Solar System;
- how far away Earth is from the Sun.



20 - 1 =

13 + 7 =

16 - 15 =

12 + 6 =

9 + 10 =

Word: _____

10 + 4 =

15 - 10 =

8 + 8 =

20 + 0 =

25 - 4 =

7 + 7 =

13 - 8 =

Word: _____

12 - 9 =

7 + 8 =

5 + 8 =

12 - 7 =

12 + 8 =

15 + 4 =

Word: _____

6 + 7 =

16 - 11 =

10 + 8 =

7 - 4 =

14 + 7 =

26 - 8 =

31 - 6 =

Word: _____

Look at the next slide to check your answers.

Solar System Code Breaker Answers

$20 - 1 = 19$

$13 + 7 = 20$

$16 - 15 = 1$

$12 + 6 = 18$

$9 + 10 = 19$

Word: **Stars**

$10 + 4 = 14$

$15 - 10 = 5$

$8 + 8 = 16$

$20 + 0 = 20$

$25 - 4 = 21$

$7 + 7 = 14$

$13 - 8 = 5$

Word: **Neptune**

$12 - 9 = 3$

$7 + 8 = 15$

$5 + 8 = 13$

$12 - 7 = 5$

$12 + 8 = 20$

$15 + 4 = 19$

Word: **Comets**

$6 + 7 = 13$

$16 - 11 = 5$

$10 + 8 = 18$

$7 - 4 = 3$

$14 + 7 = 21$

$26 - 8 = 18$

$31 - 6 = 25$

Word: **Mercury**

Design a Planet

You have discovered a brand new planet! Complete an astronaut report to send to Mission Control about what you have found.

Key Facts

Colour: _____

Size: _____

Number of moons: _____

Inhabitants

(People Who Live There)

Name of Planet: _____

Other information: _____

Surface

Materials: _____

Signs of life (water, oxygen):



The Solar System

a b c d e f p h i j k l
 p l u t o r l t u u w x
 y z a b c d a f g p i j
 k l m n o v n r s i u v
 w x e z a b e a r t h q
 m j r l m n t n q e s t
 a v c x y s a t u r n f
 r h u j k u m n o s q r
 s t r v w n e p t u n e
 e t y h i j k l m n o p
 q r a t u r a n u s a b
 c d e r g h i j k l m n

Mercury	Jupiter	Pluto
Venus	Saturn	Star
Earth	Uranus	Planet
Mars	Neptune	Sun

Space Crossword

Amazing Fact

Space is totally silent because there is no air to carry vibrations.

Challenge

Try out your space knowledge by completing this crossword.

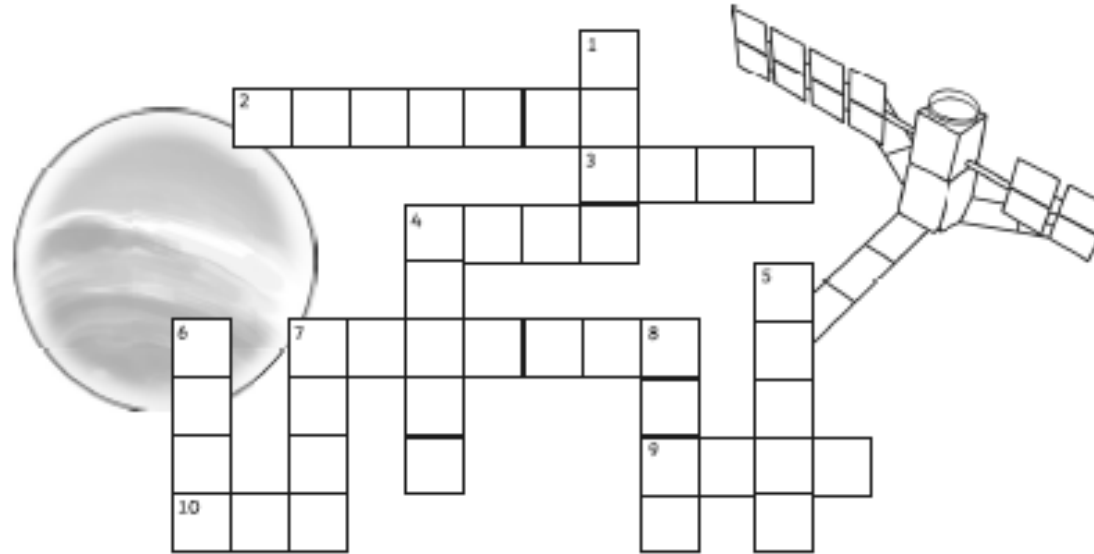

Across

- 2 The 8th planet from the Sun.
- 3 Another word for the Sun.
- 4 The Sun rises in the _____.
- 7 The planet nearest the Sun.
- 9 The Earth spins on its _____.
- 10 The middle of the solar system.

Down

- 1 The Sun sets in the _____.
- 4 A blue planet that has water.
- 5 The path of a planet around the Sun.
- 6 The next planet from the Sun after Earth.
- 7 It takes 28 days to go round the Earth.
- 8 The time it takes for the Earth to go round the Sun.

You could also try to find out:

- how communication works in space;
- what speeds objects are able to travel at in space;
- if there are any soundless places on earth;
- what else would be affected by an absence of air.

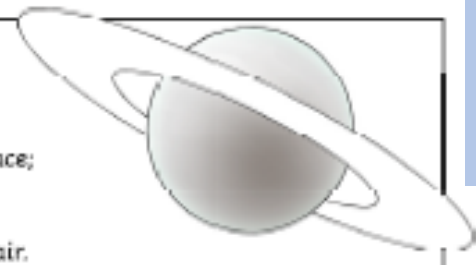

Look at the next slide for crossword answers.

Solar System Fact Hunt



Use books, the Internet or the Solar System Fact Cards to find the answers to the following questions.

Which planet orbits closest to the Sun? _____	Which planet has the highest maximum temperature? _____
Which planet's atmosphere contains the highest percentage of carbon dioxide? _____	How much bigger is Earth than Mars? _____
Which planet has the shortest day? _____	Which planets are made of gas? _____
Which planet has the most moons? _____	What is the Earth's atmosphere made mostly of? _____

Use the mnemonic 'My Very Easy Method Just Speeds Up Naming Planets' to remember the order of the planets from the sun. Pluto is now considered to be a dwarf planet but it is still a useful rhyme to help order the 8 planets in our Solar System.

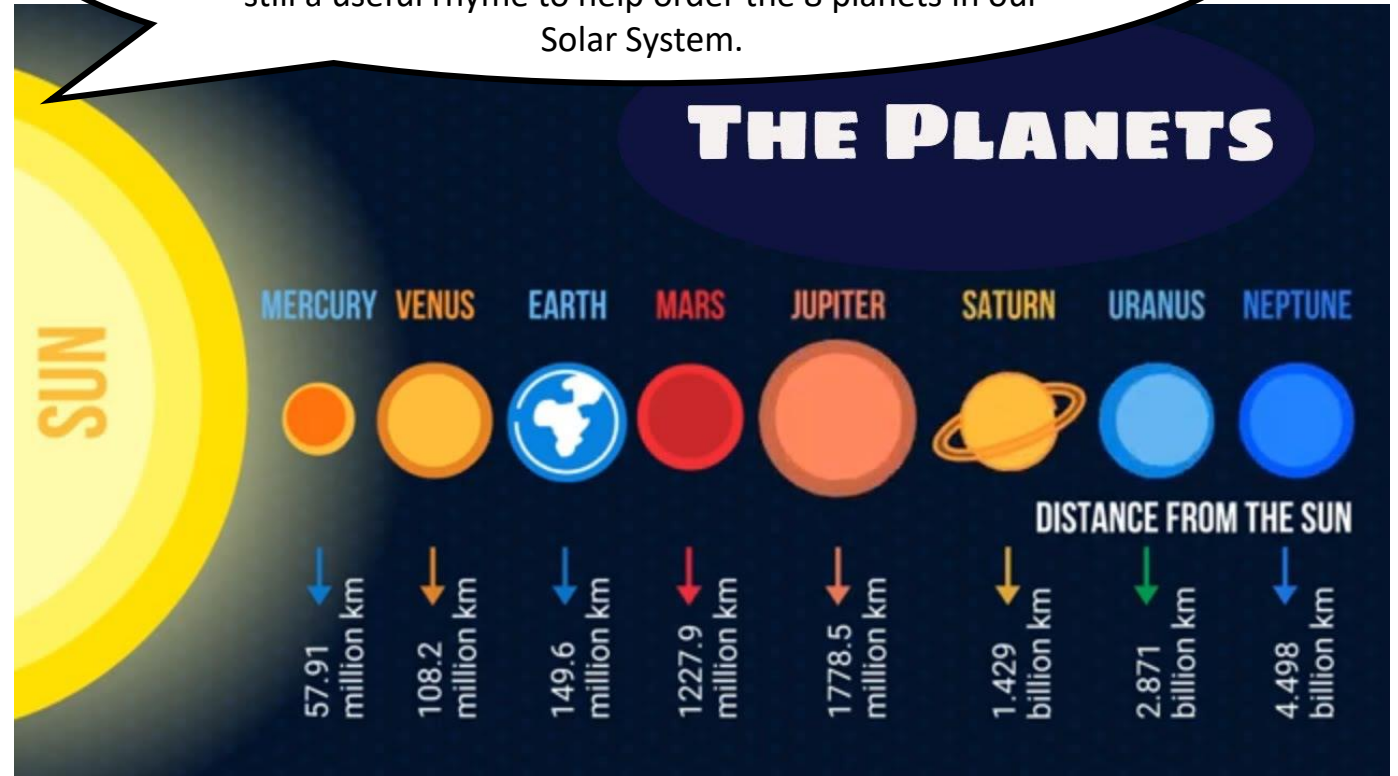

See the fact cards on slide 26 and 27. Remember you can also use the internet and books to carry out your research.

Challenge: Can you create your own fact hunt for someone in your family to complete? It could be about the Solar System or a different subject of your choice.

Mercury



Size (diameter):	4879.4km
Moons:	0
Distance from Sun:	53.29 million km
Length of year:	88 days
Length of day:	58 days 15 hours 30 minutes
Temperature:	-173°C to 427°C
Atmosphere:	
hydrogen, helium, oxygen, sodium and potassium	

Venus



Size (diameter):	12 104km
Moons:	0
Distance from Sun:	107.48 million km
Length of year:	225 days
Length of day:	116 days 18 hours 0 minutes
Temperature:	around 470°C
Atmosphere:	
carbon dioxide (96.5%), nitrogen and sulphur dioxide	

Earth



Size (diameter):	12 742km
Moons:	1
Distance from Sun:	151.75 million km
Length of year:	365 days
Length of day:	24 hours
Temperature:	between -88°C and 58°C
Atmosphere:	
Nitrogen	78.08%
Oxygen	20.95%
Argon	0.93%
Carbon dioxide	0.04%

Mars



Size (diameter):	6 791km
Moons:	2 (Phobos and Deimos)
Distance from Sun:	227.9 million km
Length of year:	687 days
Length of day:	1 day 0 hours 37 minutes
Temperature:	between -140°C and 20°C
Atmosphere:	
Oxygen: 0.13%, CO ₂ : 95.32%	
CO: 0.08%, N: 2.7%, Ar: 1.6%	

Jupiter



Size (diameter):	139 822km
Moons:	79
Distance from Sun:	778.89 million km
Length of year:	12 years
Length of day:	9 hours 56 minutes
Temperature:	about -145°C
Atmosphere:	
This planet is made up mostly of gas. Almost the entire planet is made up of hydrogen and helium, with traces of ammonia, sulphur and water vapour.	

Saturn



Size (diameter):	116 464km
Moons:	82
Distance from Sun:	1.5 billion km
Length of year:	29 years
Length of day:	10 hours 42 minutes
Temperature:	between -185°C and -122°C
Atmosphere:	
This planet is made up mostly of gas. Almost the entire planet is made up of hydrogen (~75%), helium (~25%) and traces of methane and water.	

Uranus

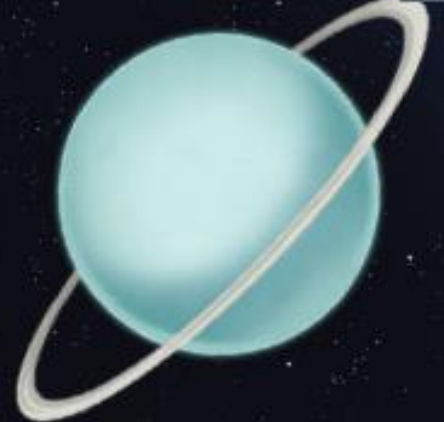

Size (diameter):	50 724km
Moons:	27 (Titania, Oberon, Miranda, Ariel, Umbriel, etc.)
Distance from Sun:	2.94 billion km
Length of year:	84 years
Length of day:	17 hours 14 minutes
Temperature:	around -224°C
Atmosphere:	
This planet is made up mostly of gas. Almost the entire planet is made up of hydrogen and helium, with traces of ammonia, water and methane.	

Neptune



Size (diameter):	49 244 km
Moons:	13 confirmed, 1 provisional
Distance from Sun:	4.48 billion km
Length of year:	165 years
Length of day:	16 hours 6 minutes
Temperature:	around -210°C
Atmosphere:	
This planet is made up mostly of gas. Almost the entire planet is made up of hydrogen, helium and methane.	